

CP66 Series

The most robust pneumatic nutrunner in its class



People.
Passion.
Performance.



Chicago
Pneumatic

CP6613/26/41 Series

The most robust pneumatic nutrunner in its class

A handy tool for flange-related and other bolting applications in the oil & gas, power generation, and wind energy segments. The CP66 nutrunner series will also be a valuable asset for remanufacturing, maintenance, repair and overhaul operations in the mining, off-road and heavy-truck segments.

ROBUST

- Replaceable protective cover with integrated bumper
- Reliable gearbox : 13000 cycles before maintenance
- Vane type high performance air motor same as industrial impact wrench

ERGONOMIC

- Special Chicago Pneumatic design grip
- Lightweight
- Swiveling handle
- One-finger reverse mode



ACCURATE

- High tightening accuracy: +/- 5%
- With ATC Pack:
 - Precise air pressure adjustment with digital gauge
 - Pressure drop checking for torque validation

VERSATILE

- Continuous rotation for any heavy duty fastening
- Effortless access to the tightening point with one of the smallest gearboxes in this tool category



STRONG LIGHT WEIGHT REACTION ARM

- Weldom700 material
- Less strain on operator
- Different arm types and shapes available

AIR TORQUE CONTROL (ATC) FRL PACK

Great accuracy with a fine pressure adjustment

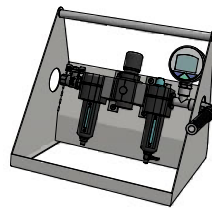

Combine the CP66 nutrunners with the most ergonomic air supply solution, for high torque tightening and pressure drop display

INDUSTRIAL FRL

- 50 l/s max air flow
- Automatic drain valve water
- Metallic bowls material

DIGITAL GAUGE

- Extremely precise pressure set up
- Pressure drop display
- Ergonomic display

ROBUST

- Strong metallic FRL portable stand
- Industrial calibrated digital gauge

Model	Part #	Square Drive	Bolt size		Free Speed at 6.3 bars RPM	Minimum Torque at 1.5 bar		Max Torque at 6.3 bars		Air Cons. @ Load		Tool Weight without reaction arm		Tool Weight with reaction arm		Sound Pressure dB(A)	Air inlet thread (NPT)	Vibration m/s ²
			mm	in.		ft-lbs.	Nm	ft-lbs.	Nm	cfm	l/s	lbs.	kg	lbs.	kg			
CP6613 + ATC Pack	615 180 0120	3/4"	20-27	3/4	20	236	320	960	1300	48	23	8.3	3.7	10.1	4.4	90	3/8	<2.5
CP6613 tool only	615 180 0090			1-1/16														
CP6626 + ATC Pack	615 180 0130	1"	20-36	3/4	10	520	700	1900	2600	48	23	11.2	5.1	14.3	6.5	90	3/8	<2.5
CP6626 tool only	615 180 0100			1-3/8														
CP6641 + ATC Pack	615 180 0140	1"	30-45	1-3/16	10	738	1000	3100	4100	65	31	19.4	8.8	23.8	10.8	90	3/8	<2.5
CP6641 tool only	615 180 0110			1-3/4														

Hose int. 5/8" (9.5mm) for CP66 series. Air pressure range from 21.7 PSI (1.5 Bar) to 90 PSI (6.3 Bars)
For all models: declared noise and vibration emissions according to ISO 28927-2 and ISO 15744.
Dimension details on back cover.

Listed specifications are for reference only.
Please check tool documentation.

EXCELLENT CUSTOMER VALUES

- **Better operator comfort:** lightweight and easy to handle, it reduces operator fatigue as well as risks of MSDs* and operates with little vibration and low noise levels (90 dB)
- **Tightening error-proof:** high accuracy of +/-5% combined with the ATC FRL pack for air pressure drop check and precise adjustment
- **Lasts longer, more durable:** strong and powerful gearbox design with a motor housing protective cover requiring maintenance only every 13,000 cycles
- **Effortless access to bolts:** Highly compact tool due to its small gearbox and weighing as little as 3.7kg
- **Reduces fatigue while delivering optimum performance:** Its strong, light weight (SLW) reaction bar is extremely durable and absorbs the torque delivered by the nutrunner's powerful but compact gearbox, as well as stabilizing the tool and distributing its weight during operation

THE BENEFITS OF THE NUTRUNNER TECHNOLOGY

- Little vibration and much lower noise levels (90 dB vs. 105 dB)
- Light weight and easy to handle

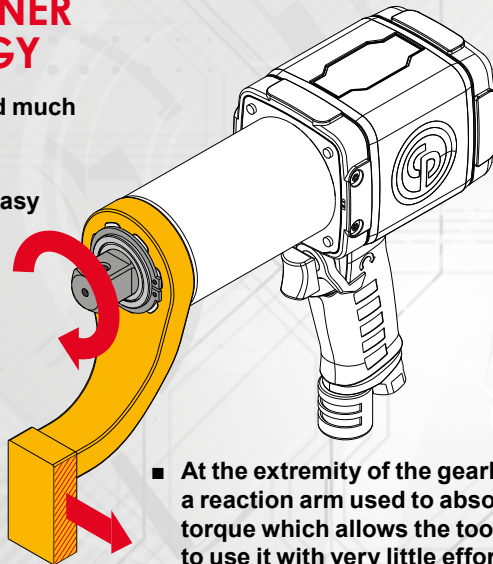

- At the extremity of the gearbox is a reaction arm used to absorb the torque which allows the tool operator to use it with very little effort.

*MUSCULOSKELETAL DISORDERS (MSDs) RISKS REDUCTION

The CP66 has been designed with operator safety in mind as the torque is **reached smoothly and not by hammering** like it would happen with an impact wrench.

It therefore operates with very little vibration (<2.5 m/s²) and its strong, light weight (SLW) **reaction bar absorbs the torque** delivered by the nutrunner's gearbox and distributes its weight during operation.

All of these features, as well as the 360° rotative handle, reduce the risks of musculoskeletal disorders (MSDs) usually caused by repeated long-term impact wrenches use.

FOR BOLTING APPLICATIONS, MAINTENANCE AND OVERHAUL OPERATIONS



HEAVY TRUCK MAINTENANCE

Cylinder head, trailer maintenance, tire changing, brake maintenance, agricultural and road, construction equipment, medium and heavy duty trucks and tractor trailers



MINING AND MINERAL PROCESSING

Track maintenance, undercarriage maintenance, wheel maintenance, shovel maintenance, caterpillar screws



POWER GENERATION

Turbine bolts, tower segments, turbine casings



OIL, GAS & PETROCHEMICAL

Pipe flanges, valves, Manway covers, pressure vessels



Over 110 years of experience

Since 1901 the Chicago Pneumatic (CP) name has represented reliability and attention to customer needs, with construction, maintenance and production tools and compressors designed for specific industrial applications. Today, CP has a global reach, with local distributors around the world.

Our people start every single day with a passion to research, develop, manufacture and deliver new products that are meant to meet your needs not only today, but tomorrow as well.

To learn more about our extensive range of tools, construction equipment, industrial and portable compressors, accessories and workshop equipment, please visit www.cp.com.



DIMENSIONS

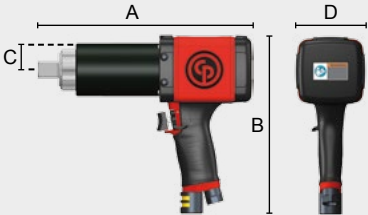

Model	A		B		C		D	
	in.	mm	in.	mm	in.	mm	in.	mm
CP6613	10	254	8.34	212	1.26	32	2.83	72
CP6626	11.81	300	8.34	212	1.34	34	2.83	72
CP6641	14.21	361	8.97	228	1.57	40	3.94	100

CP66 SERIES SPECIFIC ACCESSORIES

Model	S Type reaction arm
CP6613	615 813 1800
CP6626	615 813 1810
CP6641	615 813 1820



Model	Square bracket
CP6613	615 813 1890
CP6626	615 813 1900
CP6641	615 813 1910



Model	Steel space bar
CP6613	615 813 1830
CP6626	615 813 1840
CP6641	615 813 1850



Model	Suspension yoke
CP6613	615 813 1770
CP6626	615 813 1780
CP6641	615 813 1790



Model	Sliding-drive
CP6613	615 813 1860
CP6626	615 813 1870
CP6641	615 813 1880



ACCESSORIES SELECTION

AIR TORQUE CONTROL FRL PACK

This pack can also be ordered directly with the tool, using the "Tool + ATC FRL Pack" part number

Model	Part #	Description
ATC FRL Pack	615 813 2090	Contains: FRL + digital gauge / 3-meter hose / Coupling
FRL + digital gauge only	615 813 2110	It is recommended to use the FRL and digital gauge with the 3-meter hose, to ensure the gauge accuracy

CP EFFI MAX 3-METER HOSE

CP EFFI is a premium line of rubber hoses

Part #	Hose Length		Hose Diam. (IDxOD)		Air Flow		Max Working Pressure	
	ft	m	in. ID	mm	cfm	l/sec	bar	PSI
615 813 2080	9.8	3	5/8	16x22.5	91.1	43	16	232

Same as the hose provided in the Air Torque Control FRL Pack

CP EFFI MAX HOSE WHIP

Part # NPT	Part # BSP	Hose Diam.		Thread Size	Hose Length	
		in.	mm	in.	ft	m
CA047271	615 811 2640	1/2	13	3/8	2.0	0.6



CP AIR FLEX 360° swivel

Part # NPT	Part # BSP	Thread Size	Max. Flow	
		in.	cfm	l/sec
894 017 1571	894 017 1570	3/8	74	35



BALANCERS

Corresp. Tool	Balancer Model	Part #	Load Range		Stroke		Net Weight	
			lb.	kg	ft	m	lb.	kg
CP6613	CP9937	894 109 9370	8.8-13.2	4.0-6.0	8.2	2.5	7.1	3.2
CP6626	CP9938	894 109 9380	13.2-17.6	6.0-8.0	8.2	2.5	7.7	3.5
CP6641	CP9939	894 109 9390	17.6-22.0	8.0-10	8.2	2.5	8.2	3.7



SERVICE

Model	MOTOR SERVICE KIT Part #	HOUSING SERVICE KIT Part #
CP6613	615 399 3810	615 399 3590
CP6626	615 399 3820	615 399 3600
CP6641	615 399 3830	615 399 3610